

Taming Complexity using Artificial and Collective intelligences: From Physics to Society

Raphaël-David Lasserri

22 March 2019, Institut Pascal, Orsay

CEA/DRF/ESNT



Magic LEMP





I

Introduction

II

Complexity and Emergence

III

Taming complexity with AI

IV

Innovation and Emergence

Introduction

*Quantum mechanics is a theory about the physical **description** of physical systems **relative** to other systems, and this is a complete description of the world¹ – Carlo Rovelli*

¹International Journal of Theoretical Physics August 1996, Volume 35, Issue 8, pp 1637–1678

Knowledge and Information

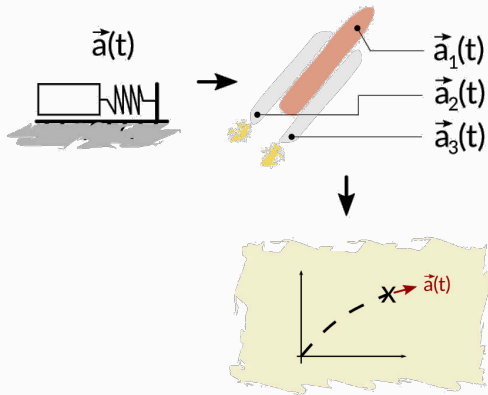

Knowledge and Information

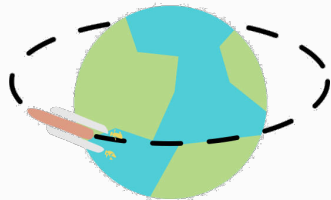
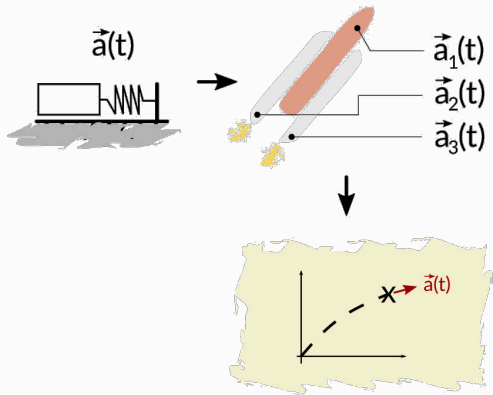

Representations

Transparent + **Explicit**

- Arithmetics
- ◇ Reductionism

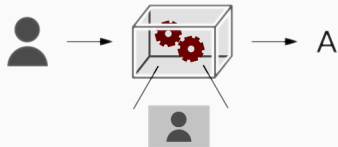

Representations

Transparent + **Explicit**

- Arithmetics
- ◇ Reductionism

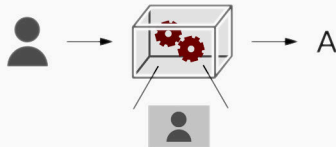

Transparent + **Implicit**

- Encrypted messages
- ◇ Emergentism

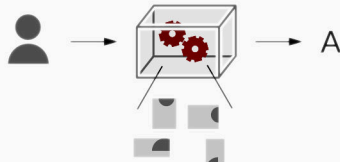

Complexity and Emergence

Scales and emergence

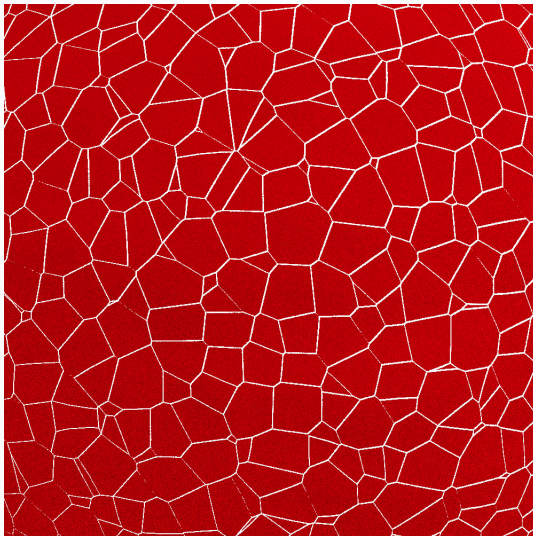

Scales and emergence

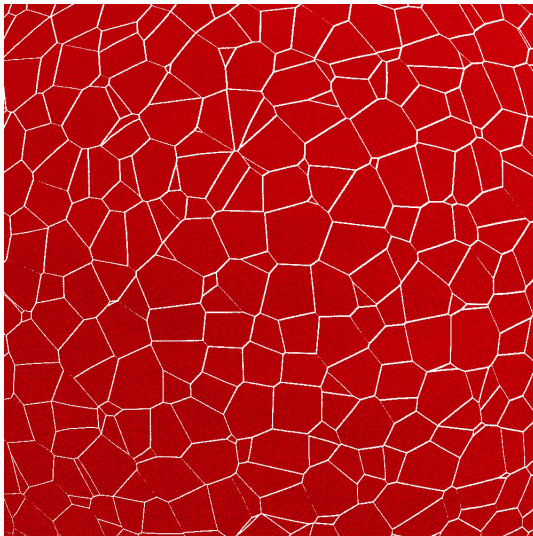

Complexity and Emergence

Complexity in Nuclear Physics

Nuclear system: Complexity and diversity

Atomic nuclei are complex many body systems:

1. Finite size.
2. Sensitive to three fundamental interactions.
3. Composed of non-elementary fermions.

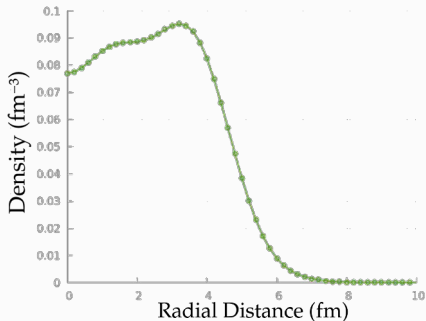

Nuclear system: Complexity and diversity

Atomic nuclei are complex many body systems:

1. Finite size.
2. Sensitive to three fundamental interactions.
3. Composed of non-elementary fermions.



Electromagnetic

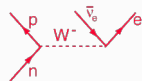

Weak

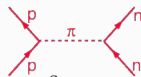

Strong

Nuclear system: Complexity and diversity

Atomic nuclei are complex many body systems:

1. Finite size.
2. Sensitive to three fundamental interactions.
3. Composed of non-elementary fermions.

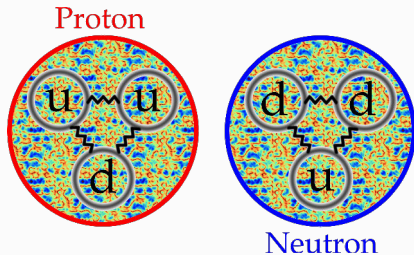

Nuclear system: Complexity and diversity

Atomic nuclei are complex many body systems:

1. Finite size.
2. Sensitive to three fundamental interactions.
3. Composed of non-elementary fermions.

Consequences

- No analytical treatment possible.
- Large number of emerging phenomena

Emerging phenomena: Collective behavior

These correlations lead to the emergence of:

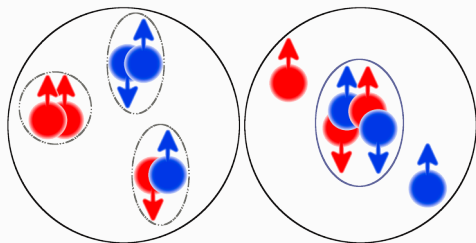

- Superfluidity
(Pairing/Quartetting)
- Spatial deformation.

Emerging phenomena: Collective behavior

These correlations lead to the emergence of:

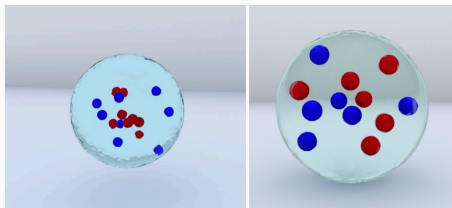

- Superfluidity
(Pairing/Quartetting)
- Spatial deformation.

Emerging phenomena: Collective behavior

These correlations lead to the emergence of:

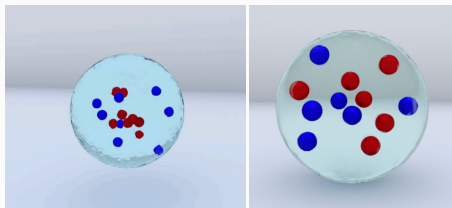

- Superfluidity
(Pairing/Quartetting)
- Spatial deformation.

Emerging phenomena: Collective behavior

These correlations lead to the emergence of:

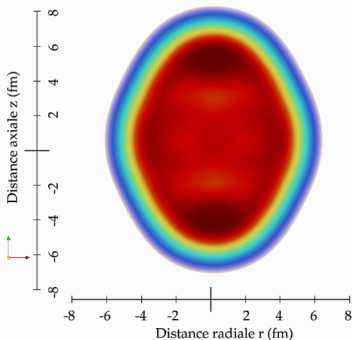

^{238}U

- Superfluidity
(Pairing/Quartetting)
- Spatial deformation.

Emerging phenomena: Collective behavior

These correlations lead to the emergence of:

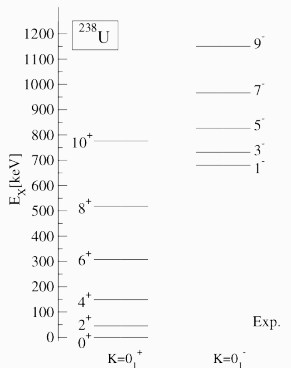

- Superfluidity
(Pairing/Quartetting)
- Spatial deformation.

Complexity and Emergence

Social complexity: The Judiciary

Legal systems are (very) complex systems too².

1. Multiplicity
2. Complexity.
3. Interdependancies.

UBU LOI, P. Sassier, D. Lansoy

- ★ 62 Codes
- ★ 10 500 Laws
- ★ 120 000 Decrees

²nosdéputés.fr

Social complexity: The Judiciary

Legal systems are (very) complex systems too².

1. Multiplicity
2. Complexity.
3. Interdependancies.

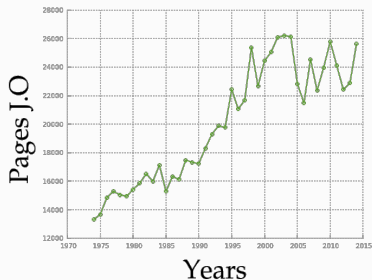

²nosdéputes.fr

Social complexity: The Judiciary

Legal systems are (very) complex systems too².

1. Multiplicity
2. Complexity.
3. Interdependancies.

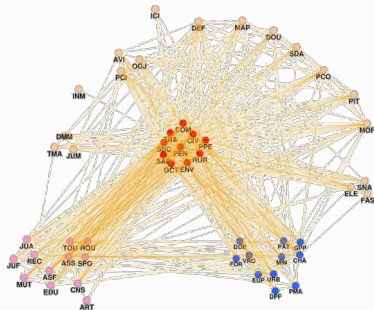

²nosdéputes.fr

Legal systems are (very) complex systems too².

1. Multiplicity.
2. Complexity.
3. Interdependancies.

Consequences

- Judiciary in a *Gazeous State*³.
- Emerging features.

²nosdéputés.fr

³DE LA SÉCURITÉ JURIDIQUE – Conseil d'état 2006

Social complexity: Emergence

Case Law (*Jurisprudence*)

Praeter legem

Non-competition clause



(2002)

Social complexity: Emergence

Case Law (*Jurisprudence*)

Praeter legem

Non-competition clause

(2002)



Intra legem

Dwarf-Tossing

(1995)

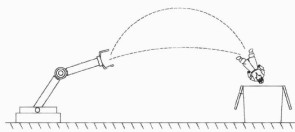

Beyond emergentism

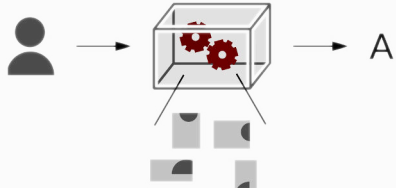
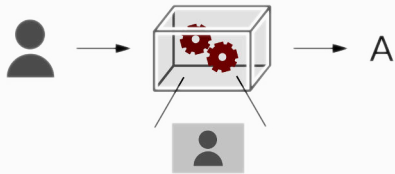

Beyond emergentism

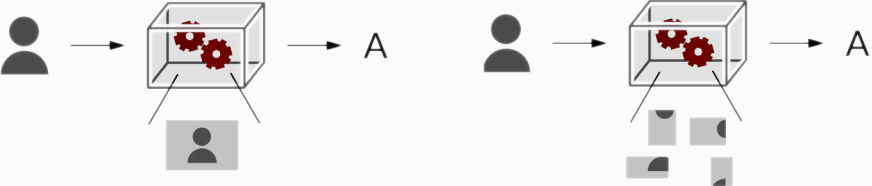

Opaque + Implicit



Taming complexity with AI

Natural representation of emerging phenomena

Representation learning:

Low level (Pixels)



Convolutional Deep Belief Networks for Scalable Unsupervised Learning of Hierarchical Representations, *Lee & al.*

Natural representation of emerging phenomena

Representation learning:

Low level (Pixels)



High Level (Faces)

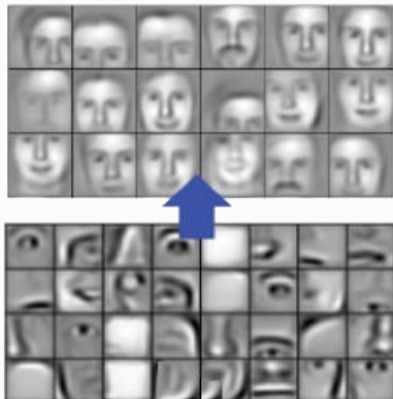

Convolutional Deep Belief Networks for Scalable Unsupervised Learning of Hierarchical Representations, *Lee & al.*

Infering new classes of correlations

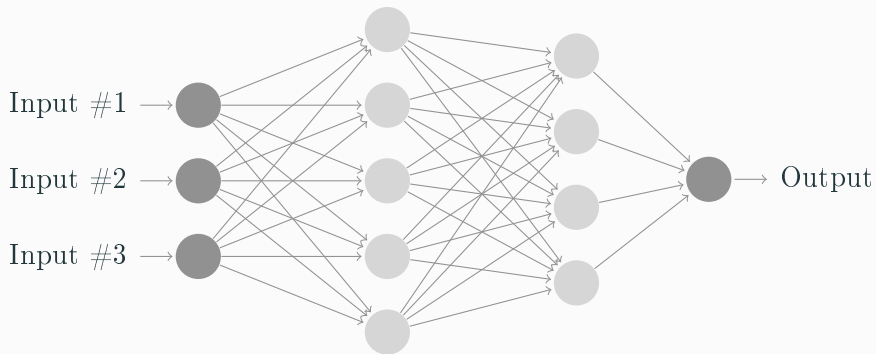

Infering new classes of correlations

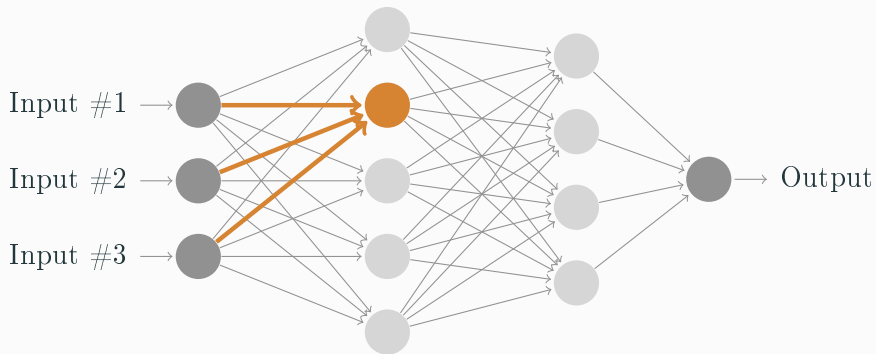

Infering new classes of correlations

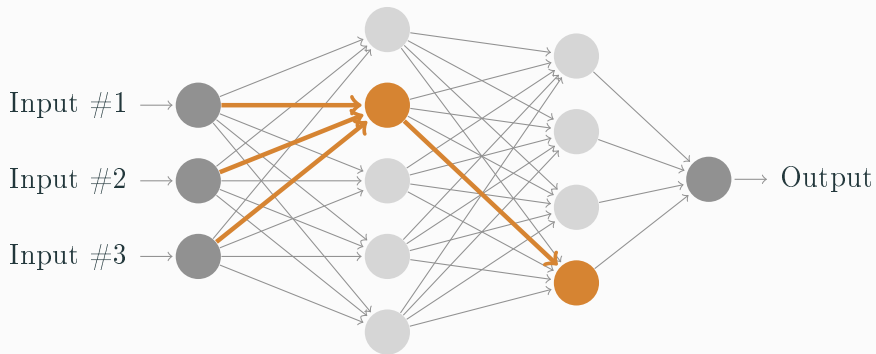

Infering new classes of correlations

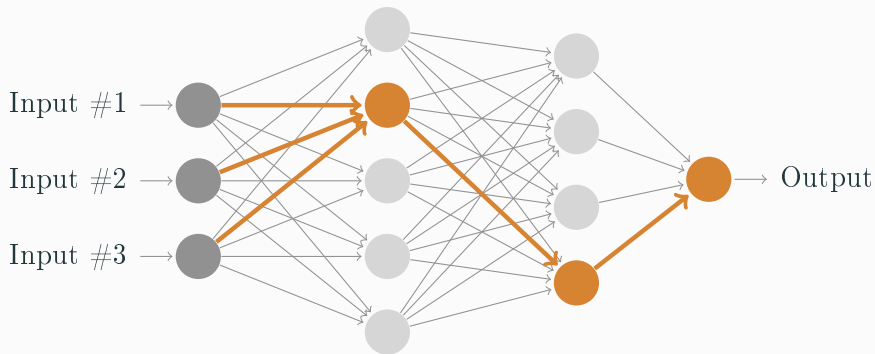

Infering new classes of correlations

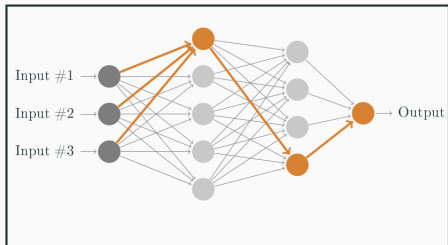

Infering new classes of correlations

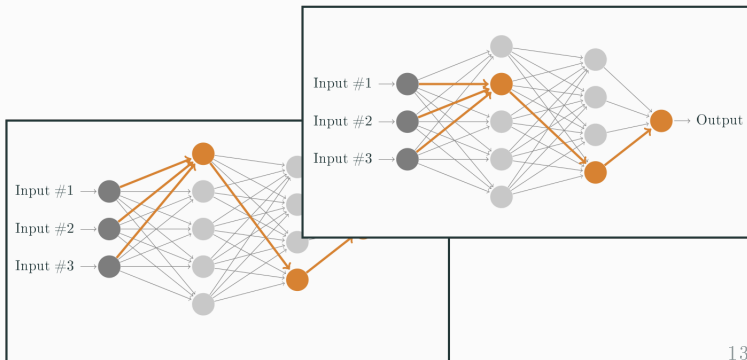

Infering new classes of correlations

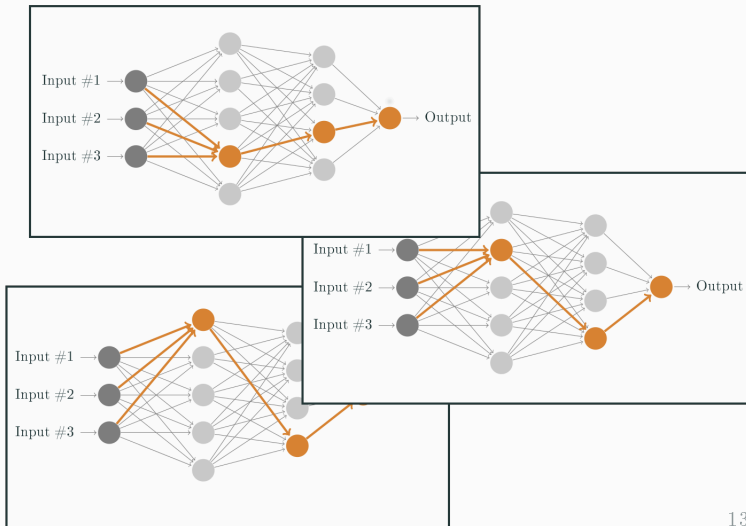

Taming complexity with AI

Model-Free Nuclear Physics

1D-PES: Argon 36

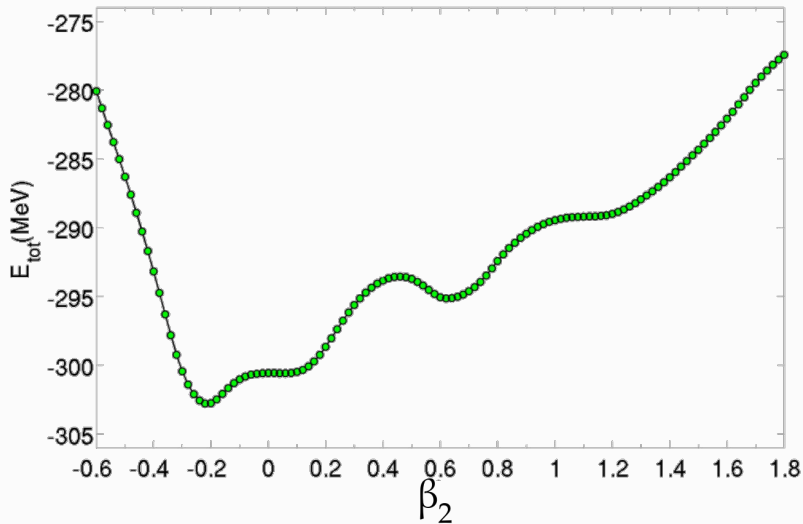

1D-PES: Argon 36

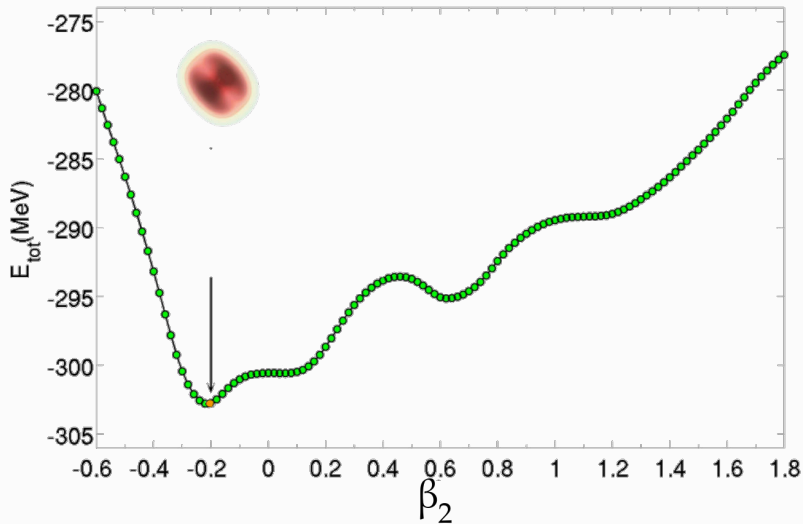

1D-PES: Argon 36

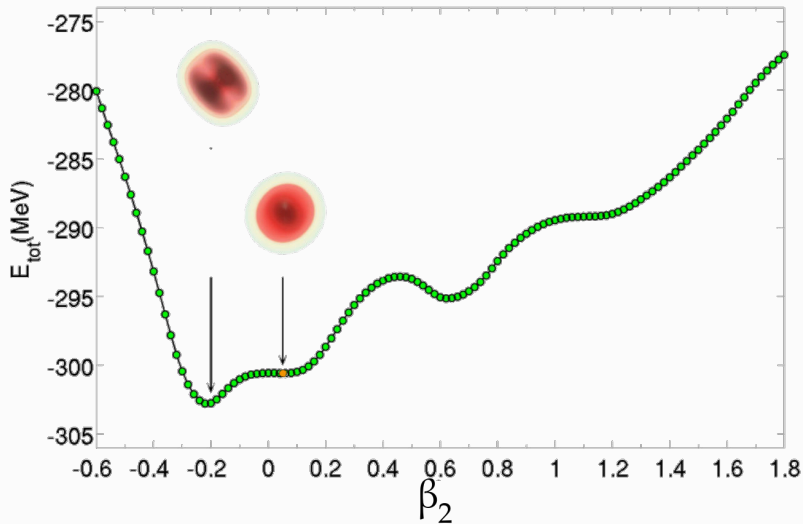

1D-PES: Argon 36

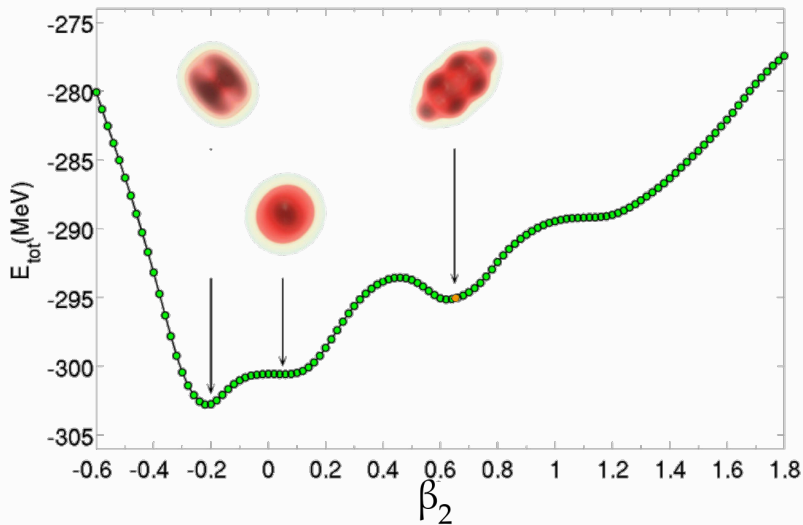

1D-PES: Argon 36

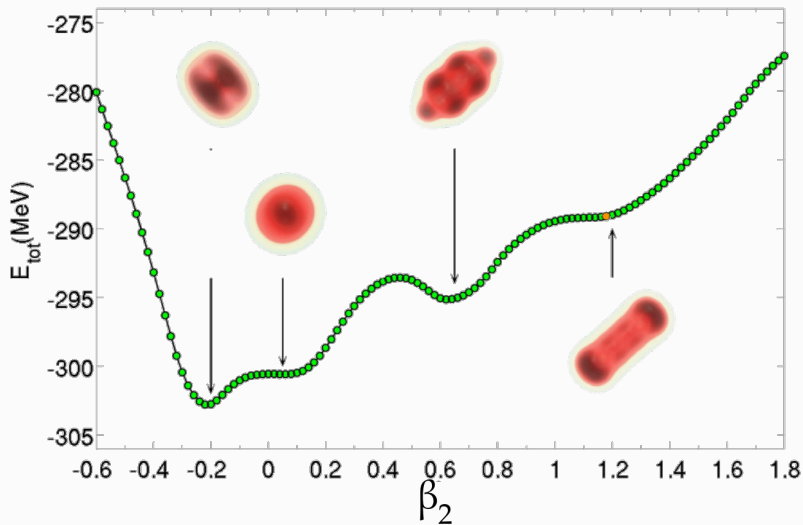

Nuclear structure: NucleAI

Deep Feed-Forward NN

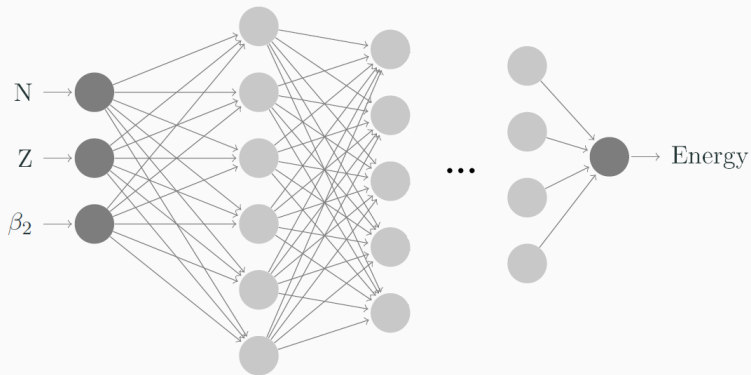

Dataset

- Training:
Meaningfull nuclei
 - Selected around magic-numbers
 - Near known drip-lines
 - Randomly picked
- 100 β_2 points
- 4000 HFB-Stable nuclei

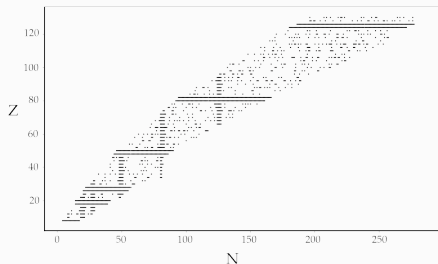

Optimization of training/testing dataset needed.

Dataset

- Training:
Meaningfull nuclei
 - Selected around magic-numbers
 - Near known drip-lines
 - Randomly picked
- 100 β_2 points
- 4000 HFB-Stable nuclei

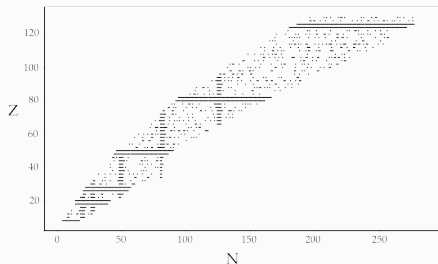

Optimization of training/testing dataset needed.

Dataset

- Training:
Meaningfull nuclei
 - Selected around magic-numbers
 - Near known drip-lines
 - Randomly picked
- 100 β_2 points
- 4000 HFB-Stable nuclei

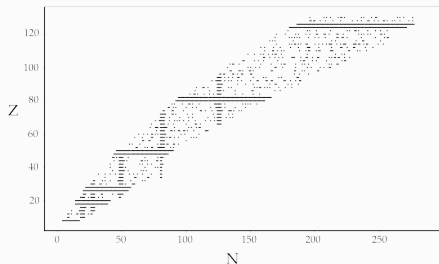

Optimization of training/testing dataset needed.

A few results

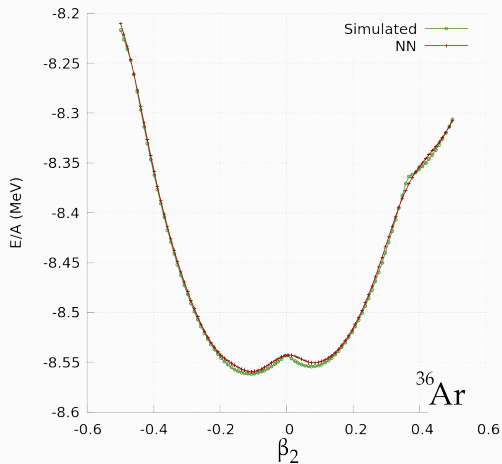

A few results

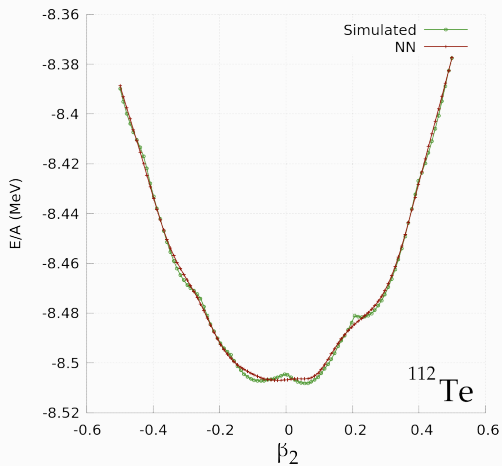

A few results

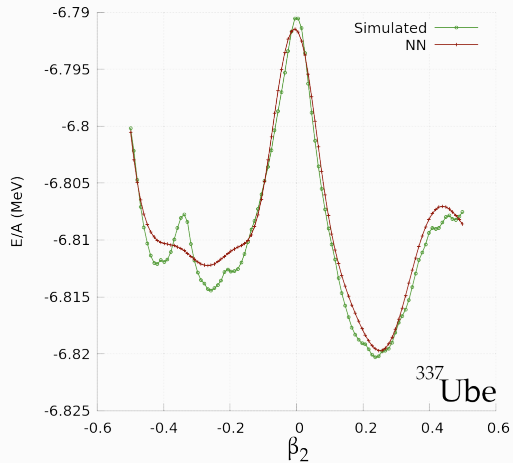

A few results

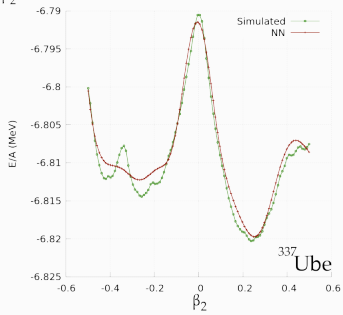
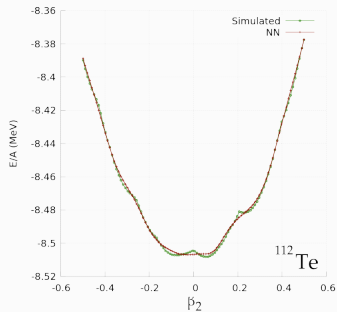
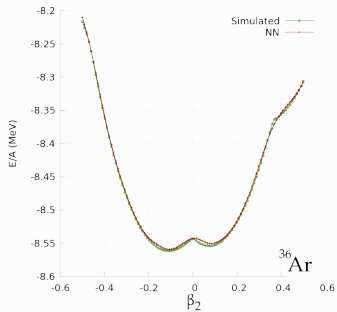

Precision on the full Chart

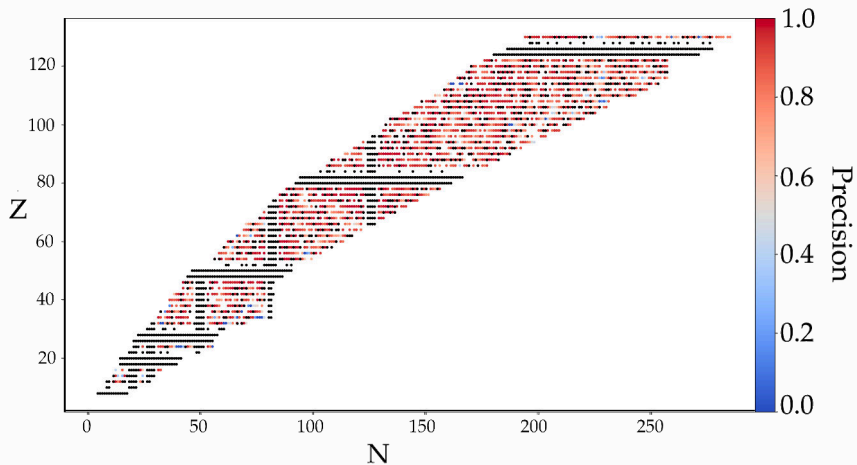

Precision on the full Chart

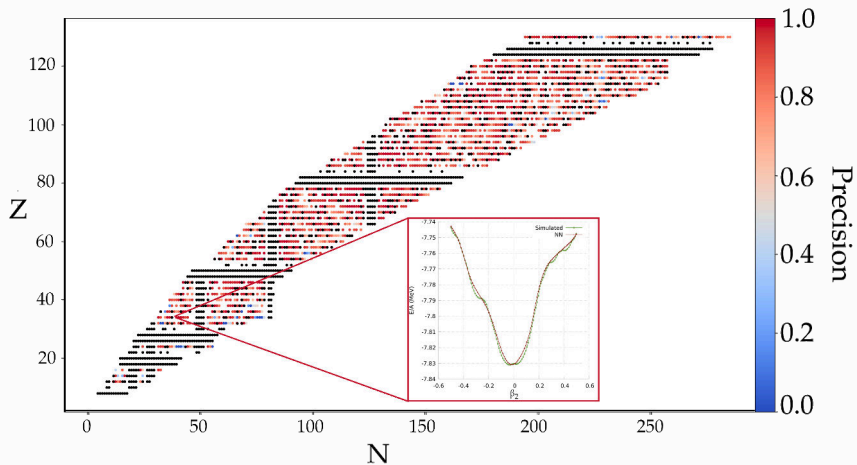

Precision on the full Chart

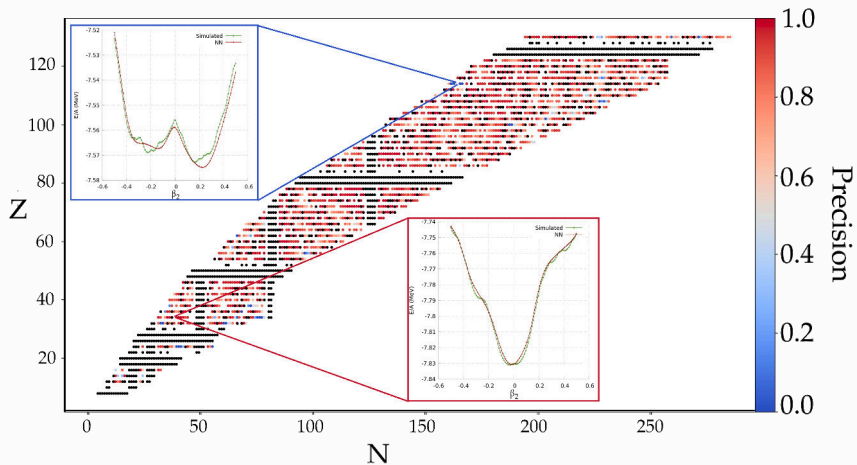

Influence of the training set

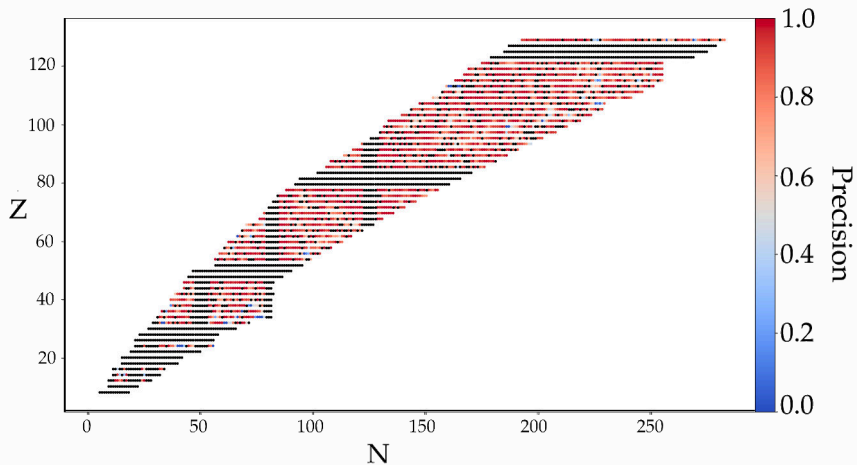

Influence of the training set

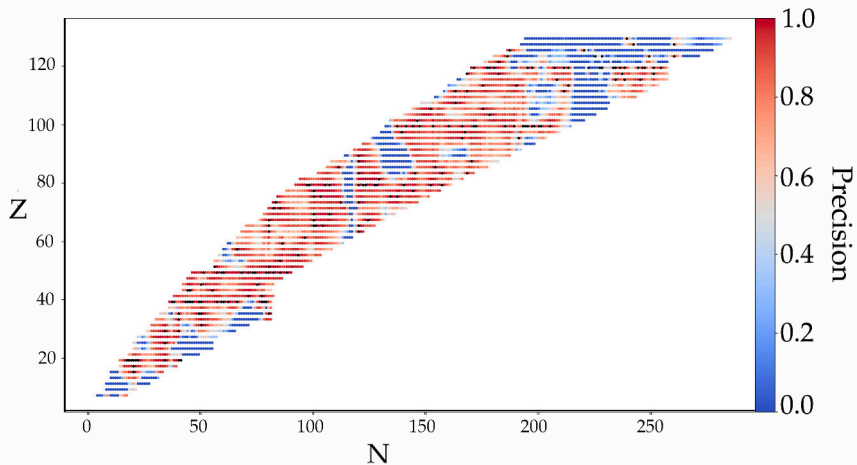

Influence of the training set

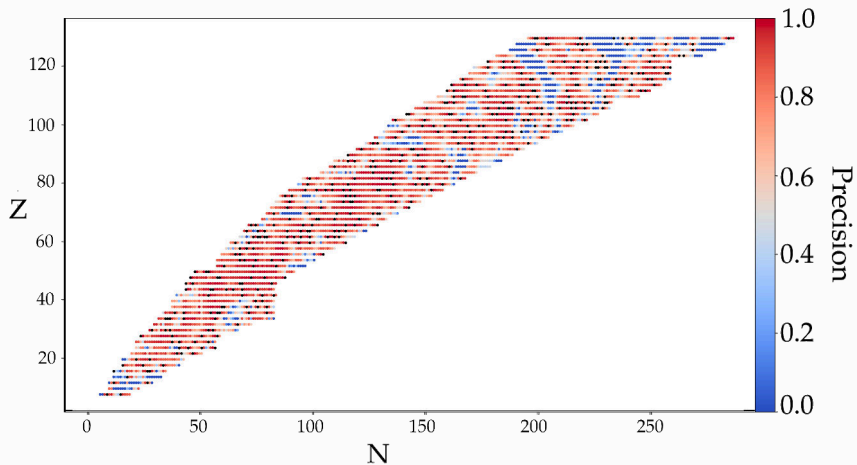

Influence of the training set

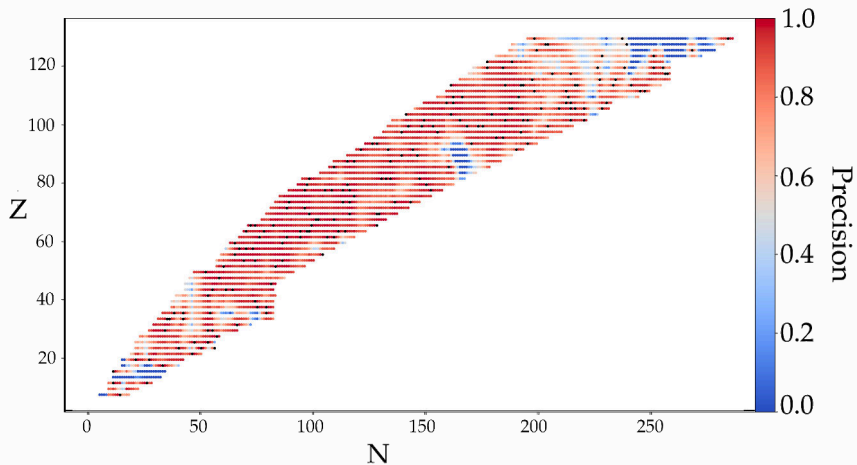

Influence of the training set

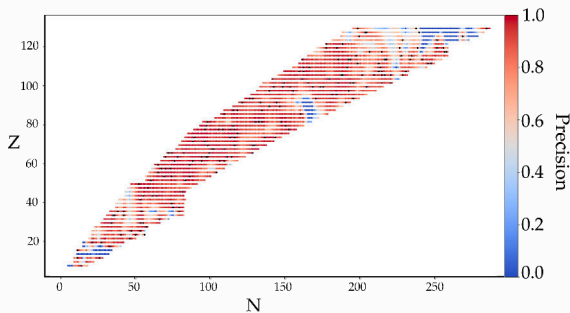

- $< 10\%$ of the Dataset
- Encodes most of the physics⁴

⁴Lasseri, Regnier, Penon, Ebran *In preparation*

Taming complexity with AI

Legal Analysis with (R)NN

Classical NLP problem:

Statuant sur l'appel → ?

Classical NLP problem:

Statuant sur l'appel. → téléphonique.

Classical NLP problem:

Statuant sur l'appel. → d'offre

Classical NLP problem:

Statuant sur l'appel → ?

Problem: Long distance correlations

Long-Short-Term-Memory



Large French Case Law Database:

- ◇ All laws/codes/Encyclopedias
- ◇ > 4.5 M Case Laws



Exemples:

Statuant sur l'appel formé par **Albert E.** à l'encontre de **Erwin S.** représenté par son conseil **Niels B.**

Application to Identification

Exemples:

Statuant sur l'appel formé par **Albert E.** à l'encontre de **Erwin S.** représenté par son conseil **Niels B.**

Considérant que **Albert E.** a attaqué Mr **Erwin S.** présent à **Solvay**, fait constaté par **Marie C.**

Application to Identification

Exemples:

Statuant sur l'appel formé par **Albert E.** à l'encontre de **Erwin S.** représenté par son conseil **Niels B.**

Considérant que **Albert E.** a attaqué Mr **Erwin S.** présent à **Solvay**, fait constaté par **Marie C.**

Applications:

- Reglementation⁵
- Abstract redaction

⁵Penon, Lasserri, Behra, Hammelin

violence en état d'ébriété

... que l'employeur se prévaut également de la réponse qui lui était adressée par M. X, le 1er juillet 2009, celui-ci ayant été cité par M. Y comme ayant été victime d'une **agression** et qui indiquait "Le policier qui m'a attrapé par le col de mon pull **était saoul** et je n'ai pas compris la raison de son geste. C'est une personne qui était avec lui qui nous a séparés..."

L. 122-4, L. 122-13 et L. 122-14-3 du Code du travail

... Attendu que M. Y, qui avait été embauché le 1er février 1996 par la société T en qualité de cadre commercial, a pris acte le 10 novembre 1998 de la **rupture de son contrat de travail aux torts de l'employeur** ; qu'il a saisi la juridiction prud'homale d'une demande tendant notamment au **paiement d'une indemnité** pour **licenciement sans cause** réelle et sérieuse ...

Nuclear Physics

- NN encodes axial-deformations
- Used as a precise starting point for HFB scheme
- ★ Going beyond mean-field using CNN

Judiciary

- Precise entity recognition
- Text correlation using ATTENTION
- ★ Case Law simulation

Summary

Nuclear Physics

- NN encodes axial-deformations
- Used as a precise starting point for HFB scheme
- ★ Going beyond mean-field using CNN

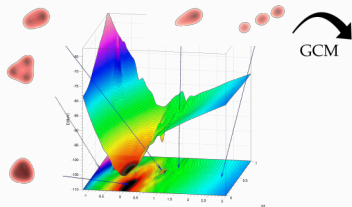

Variables

Judiciary

- Precise entity recognition
- Text correlation using ATTENTION
- ★ Case Law simulation

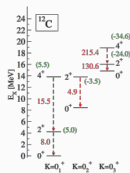

Observable

Summary

Nuclear Physics

- NN encodes axial-deformations
- Used as a precise starting point for HFB scheme
- ★ Going beyond mean-field using CNN

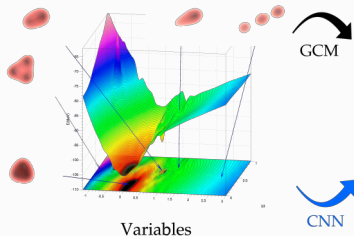

Judiciary

- Precise entity recognition
- Text correlation using ATTENTION
- ★ Case Law simulation

Nuclear Physics

- NN encodes axial-deformations
- Used as a precise starting point for HFB scheme
- ★ Going beyond mean-field using CNN

Judiciary

- Precise entity recognition
- Text correlation using ATTENTION
- ★ Case Law simulation

Nuclear Physics

- NN encodes axial-deformations
- Used as a precise starting point for HFB scheme
- ★ Going beyond mean-field using CNN

Judiciary

- Precise entity recognition
- Text correlation using ATTENTION
- ★ Case Law simulation

**Innovation: An emerging
phenomenon ?**

Lone geniuses ?

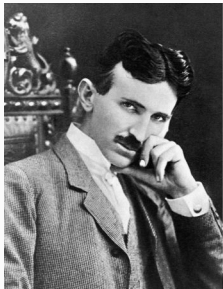

Reality

Lone geniuses ?

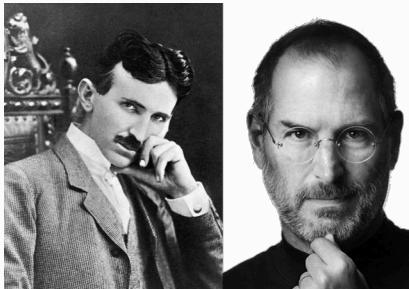

Reality or

Lone geniuses ?

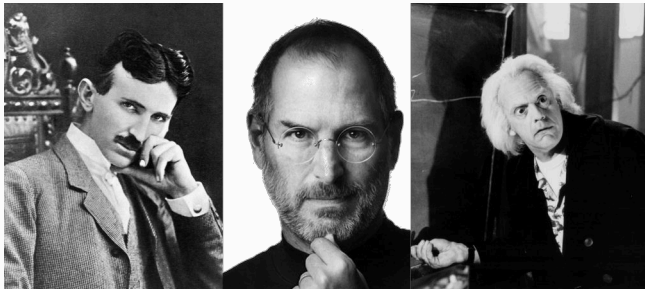

Reality or Myth ?

Ants: Complex collective system

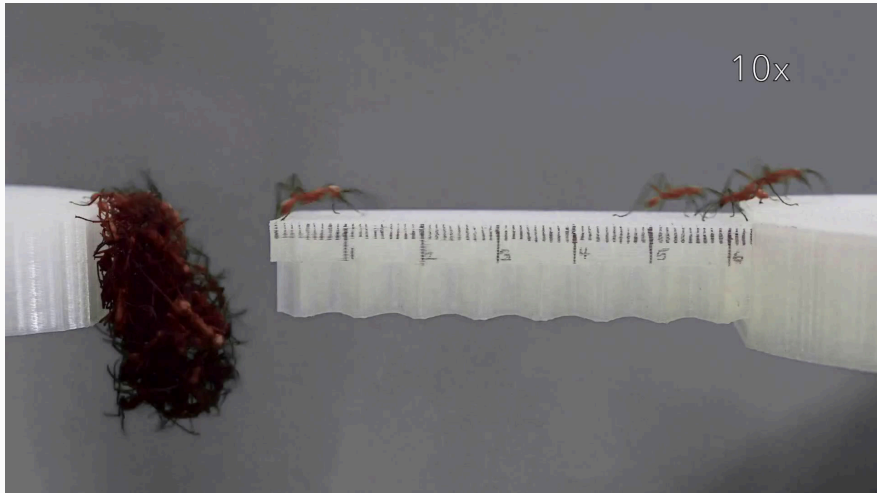

Helen McCreery, Simon Garnier - <http://www.theswarmlab.com>

Knowledge and interdisciplinarity

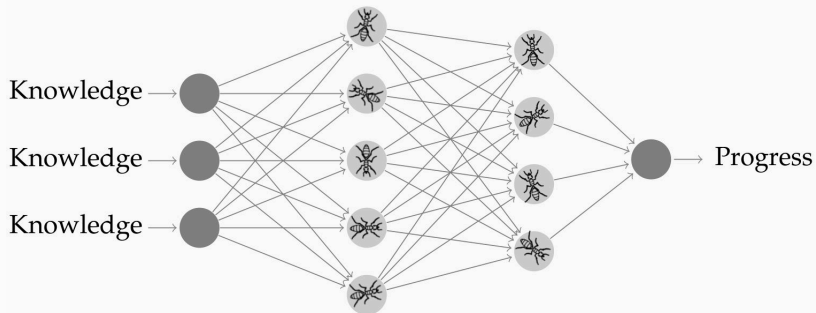

Knowledge and interdisciplinarity

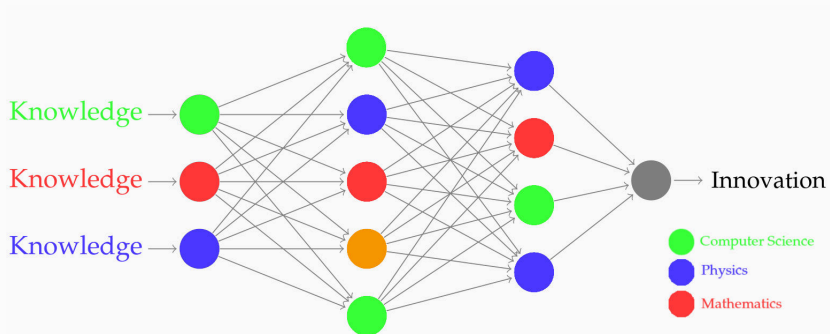

Knowledge and interdisciplinarity

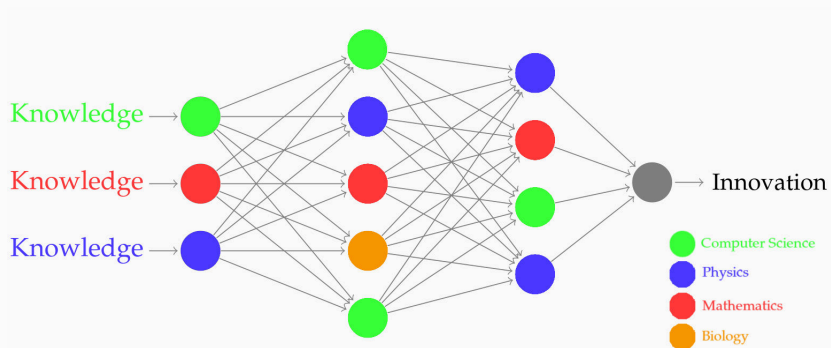

LEMP Initiative



LEMP Initiative



Merci !

Thanks for your attention !

LSTM Architecture

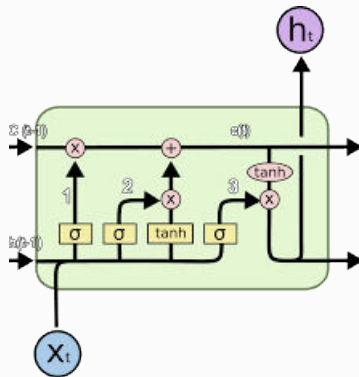

ATTENTION (1)

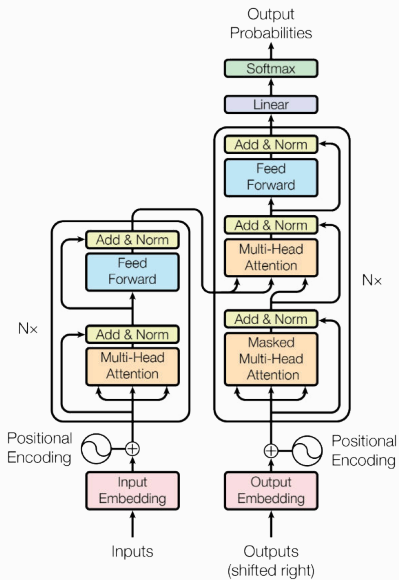

ATTENTION (1)

Scaled Dot-Product Attention

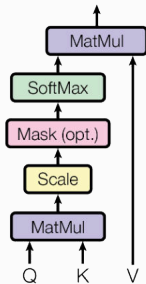

Multi-Head Attention

